

PRIVATE SEWER LATERAL AND TESTING  
PROCEDURE AND REQUIREMENTS

ORDINANCE NO. 1329, WHICH WAS ADOPTED JULY 7, 1986 AND BECAME EFFECTIVE AUGUST 7, 1986 AND WAS MODIFIED BY ORDINANCE 1623 ON MARCH 23, 2000, REQUIRES THE ABATEMENT OF SEWER LATERALS AND CLEANOUTS WHICH ARE FOUND TO CONTAIN LEAKS OR SEPARATIONS; LATERALS COVERED ARE FROM THE BUILDING SERVED TO THE CLEANOUT IN THE CITY RIGHT-OF-WAY. THE ORDINANCE ALSO REQUIRES THE TESTING AND REPAIR OF LATERALS PRIOR TO THE SALE OF THE PROPERTY IF THE BUILDING WAS CONSTRUCTED 25 YEARS OR MORE BEFORE THE DATE OF SALE. DATE OF CONSTRUCTION SHALL BE THE DATE THE BUILDING PERMIT WAS FINALED. IN ADDITION, TESTING IS REQUIRED IF TWO (2) OR MORE PLUMBING FIXTURE UNITS ARE ADDED TO A PROPERTY. THE FOLLOWING PROCEDURES AND REQUIREMENTS ARE ADOPTED TO IMPLEMENT ORDINANCE NO. 1329.

IT SHALL BE THE OWNER'S RESPONSIBILITY TO DETERMINE IF TESTING IS NEEDED. CONTACT THE BUILDING DEPARTMENT TO DETERMINE THE AGE OF THE STRUCTURE AND IF THE LATERAL HAD BEEN TESTED AND/OR REPAIRED WITHIN THE PAST TEN (10) YEARS. IT CAN BE ASSUMED THAT TESTING AND REPAIRS HAVE NOT BEEN DONE UNLESS THE PROPERTY HAS BEEN ALTERED OR SOLD AFTER AUGUST 1986. IF THE LATERAL NEEDS TESTING, THE PROPERTY OWNER SHOULD RETAIN A CONTRACTOR OR PLUMBER TO PERFORM THE TEST. THE TEST SHALL BE PERFORMED AS FOLLOWS:

1. THE TEST MUST BE WITNESSED BY A CITY REPRESENTATIVE TO MEET THE ORDINANCE REQUIREMENTS. THE CONTRACTOR OR OWNER SHALL FIRST OBTAIN AN ENCROACHMENT PERMIT FROM THE PUBLIC WORKS DEPARTMENT IN CITY HALL AND PAY AN ENCROACHMENT PERMIT FEE PER THE LATEST ENCROACHMENT PERMIT FEE SCHEDULE. OBTAINING THE PERMIT CAN BE DONE BEFORE OR CONCURRENTLY WITH SCHEDULING AN APPOINTMENT BUT IS REQUIRED AT THE TIME OF THE TEST. ALL ARRANGEMENTS AND SETUP SHOULD BE COMPLETED BY THE TIME THE CITY REPRESENTATIVE ARRIVES TO WITNESS THE TEST. CALL 650-558-7670 TO SCHEDULE AN APPOINTMENT.
2. EACH LATERAL IS TO HAVE A CLEANOUT LOCATED IN THE CITY RIGHT-OF-WAY. IF A CLEAN OUT DOES NOT EXIST, THEN ONE WILL BE REQUIRED TO BE INSTALLED. THE OWNER'S CONTRACTOR WILL INSTALL THE CLEANOUT WITH AN ENCROACHMENT PERMIT FROM THE PUBLIC WORKS DEPARTMENT. CITY PERSONNEL CAN SPEND A LIMITED AMOUNT OF TIME TO ASSIST IN LOCATING AN EXISTING CLEANOUT OR LATERAL. A CLEANOUT LOCATED ADJACENT TO THE BUILDING WILL BE AN AID IN THE TESTING PROCESS OR LOCATING THE PIPE ROUTE FOR REPAIRS AND IS NOW REQUIRED IN THE UNIFORM PLUMBING CODE. A PLUMBING PERMIT FROM THE BUILDING DEPARTMENT IS REQUIRED FOR THE CLEANOUT ADJACENT TO THE BUILDING OR ANY WORK DONE ON PRIVATE PROPERTY.
3. TESTING WILL BE ACCOMPLISHED BY EITHER A WATER EXFILTRATION TEST OR AN AIR TEST. THE AIR TEST SHALL BE USED IN HILLSIDE AREAS WHERE THE HYDRAULIC HEAD PRESSURES COULD DAMAGE THE PIPE.
  - A. WATER EXFILTRATION TEST: THE CONTRACTOR SHALL FURNISH ALL MATERIALS AND EQUIPMENT, EXCEPT THE CALIBRATED BUCKET. THE CONTRACTOR SHALL PLUG THE LATERAL AND RISER AT THE CITY CLEANOUT AND THEN SURCHARGE THE LINE WITH WATER TO A POINT EQUAL TO THE FOUNDATION'S GRADE (FLOOR JOIST LEVEL) OR CONCRETE SLAB, DEPENDING ON CONSTRUCTION. THE MINIMUM HEIGHT OF THE WATER LEVEL SHALL BE TWO FEET (2'-0") ABOVE THE FLOWLINE OF THE LATERAL AT THE CITY CLEANOUT. IF THERE IS ANY FIXTURE INSIDE THE STRUCTURE LOWER THAN THE TESTING WATER LEVEL, THE CONTRACTOR SHALL HAVE TO EITHER PLUG THE FIXTURE OR THE LATERAL AT THE BUILDING. AN APPROVED BACKWATER VALVE SHALL BE INSTALLED IF THERE ARE ANY PLUMBING FIXTURES BELOW THE LEVEL OF THE CITY CLEANOUT. A PLUMBING PERMIT IS REQUIRED FOR THIS WORK. THE CONTRACTOR MAY ALSO INSTALL OR USE AN EXISTING CLEANOUT NEAR THE STRUCTURE AT THE FOUNDATION GRADE (FLOOR JOIST LEVEL) OR CONCRETE SLAB FLOOR LEVEL TO ESTABLISH THE MINIMUM TWO FEET (2'-0") WATER LEVEL.

THE LATERAL SHALL REMAIN SURCHARGED FOR A PERIOD OF 30 MINUTES AND THE AMOUNT OF WATER LOST SHALL BE MEASURED. THE LATERAL SHALL BE CONSIDERED ACCEPTABLE IF THE AMOUNT OF WATER LOST IS LESS THAN FOUR (4) GALLONS. NO INCREASE OR ALLOWANCE IS ALLOWED FOR LONG LATERALS OR FOR LATERALS LARGER THAN THE 4-INCH MINIMUM SIZE. SEE STANDARD DRAWING SS-2 (3 OF 5).



**PRIVATE SEWER LATERAL AND TESTING  
PROCEDURE AND REQUIREMENTS**

**DEPARTMENT OF PUBLIC WORKS**

APPROVED BY

DATE

8/17/2006

DRAWING  
NO.

**SS-2**  
(1 of 4)

- B. AIR TEST: THE CONTRACTOR SHALL FURNISH ALL MATERIALS, EQUIPMENT, AND LABOR FOR MAKING THE TEST, EXCEPT THE PRESSURE TEST GAUGE. AIR TEST EQUIPMENT SHALL BE APPROVED BY THE CITY. THE CONTRACTOR SHALL CLEAN PIPE AND PLUG THE LATERAL AT THE BUILDING LINE AND THE CITY CLEANOUT [IF A CLEANOUT IS WITHIN TWO FEET (2'-0") OF THE BUILDING, THE LATERAL MAY BE PLUGGED AT THE CLEANOUT].

THE LEAKAGE TEST OF THE LATERAL SHALL BE CONDUCTED IN THE PRESENCE OF THE CITY IN THE FOLLOWING MANNER:

AIR SHALL BE SLOWLY SUPPLIED TO THE PLUGGED LATERAL UNTIL THE INTERNAL AIR PRESSURE REACHES 4.0 POUNDS PER SQUARE INCH GREATER THAN THE AVERAGE BACK PRESSURE OF ANY GROUNDWATER THAT MAY SUBMERGE THE PIPE. THE AIR PRESSURE SHALL BE REGULATED BY A SUITABLE REGULATOR VALVE.

AT LEAST TWO MINUTES SHALL BE ALLOWED FOR TEMPERATURE STABILIZATION BEFORE PROCEEDING FURTHER. THE RATE OF AIR LOSS SHALL THEN BE DETERMINED BY MEASURING THE TIME INTERVAL FOR THE INTERNAL PRESSURE TO DECREASE FROM 3.5 TO 2.5 POUNDS PER SQUARE INCH GREATER THAN THE AVERAGE BACK PRESSURE OF ANY GROUNDWATER THAT MAY SUBMERGE THE PIPE.

THE LATERAL SHALL BE CONSIDERED ACCEPTABLE IF THE TIME INTERVAL MEASURED FOR THE INTERNAL PRESSURE TO DROP FROM 3.5 TO 2.5 POUNDS PER SQUARE INCH IS 10 SECONDS OR GREATER. SEE STANDARD DRAWING SS-2 (4 OF 5).

4. IF THE LATERAL PASSES THE TEST, IT SHALL BE CERTIFIED AS ACCEPTABLE AND THE SALE CAN TAKE PLACE WITHOUT ANY FURTHER ACTION. THE CERTIFICATION SHALL BE PLACED IN THE BUILDING DEPARTMENT FILE. THIS CERTIFICATION SHALL BE EFFECTIVE FOR TEN (10) YEARS.

IF THE LATERAL FAILS THE TEST, THE LATERAL SHALL BE EITHER REPAIRED OR REPLACED AND THEN RETESTED UNTIL THE LATERAL PASSES. THERE WILL BE NO ADDITIONAL FEE FOR RETEST ON REPAIRED OR REPLACED PIPING. A PLUMBING PERMIT WILL BE REQUIRED FOR ANY REPAIRS OR REPLACEMENT. AN ENCROACHMENT PERMIT MAY ALSO BE REQUIRED DEPENDING ON THE LOCATION OF THE REPAIR. A COMPLETE REPLACEMENT FROM BUILDING TO CITY CLEANOUT IS EFFECTIVE FOR 25 YEARS. A REPAIRED AND TESTED LATERAL IS EFFECTIVE FOR TEN (10) YEARS.

5. THE CITY NEITHER HAS NOR WILL MAKE ANY DETERMINATION AS TO WHO WILL PAY FOR THE TESTING AND REPAIRING. THAT IS TO BE DECIDED BETWEEN THE PARTIES INVOLVED IN THE SALE.



**PRIVATE SEWER LATERAL AND TESTING  
PROCEDURE AND REQUIREMENTS**

**DEPARTMENT OF PUBLIC WORKS**

APPROVED BY

DATE  
8/17/2006

DRAWING  
NO.

**SS-2**  
(2 of 4)



**SEWER LATERAL TEST (WATER)  
CITY ORDINANCE #1329**

**DEPARTMENT OF PUBLIC WORKS**

APPROVED BY  
  
DATE  
8/17/2006

DRAWING NO.  
**SS-2**  
(3 of 4)

STREET OR ALLEY AREA

- 1a. BUILDING MUST HAVE CITY CLEAN-OUT IN RIGHT-OF-WAY AREA, OR OWNER MUST INSTALL NEW CITY CLEANOUT.
- 1b. CITY REPLACES "P" TRAPS IN RIGHT-OF-WAY ONLY.
2. TO PERFORM TEST, DOUBLE PLUG IS REQUIRED BY OWNER/CONTRACTOR.
3. AFTER TEST, CITY WILL LISTEN FOR WATER FROM TEST FIXTURE WHEN PLUG IS REMOVED TO CONFIRM LINE IS OPEN AND NOT PLUGGED ELSEWHERE.

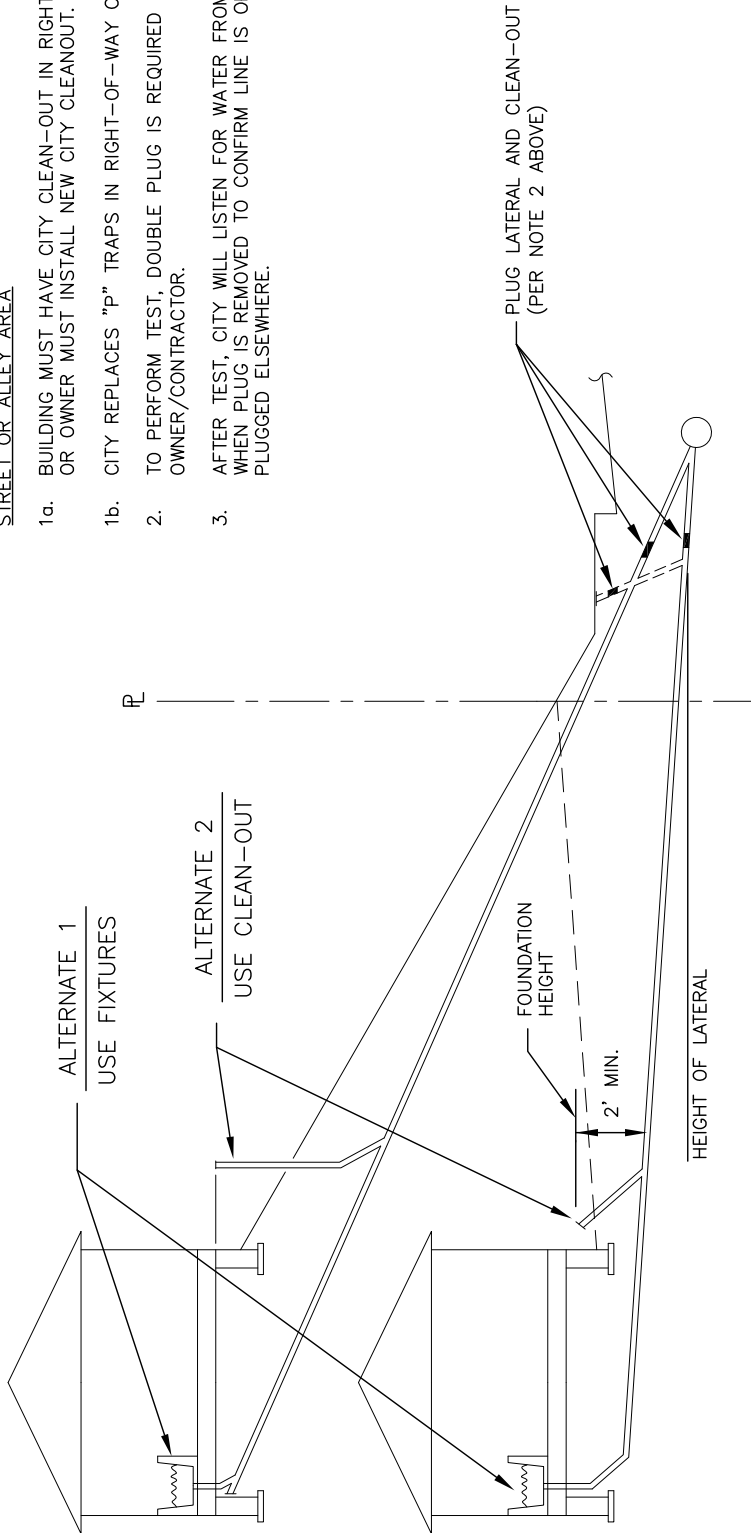

TEST PROCEDURE

- ALTERNATE 1 -
- 1a. USE LOWEST FIXTURE WHICH IS A MINIMUM OF 2' ABOVE THE LATERAL ELEVATION AT CLEAN-OUT
  - 1b. CHECK THE BASEMENT DRAINS OR SUMP PUMP.
  - 1c. REMOVE AND PLUG ALL ILLEGAL CONNECTIONS (i.e. ROOF DRAINS AND SUMP PUMP.)
  2. FILL FIXTURE UNTIL WATER DOES NOT DRAIN.
  3. MARK WATER LEVEL.
  4. SHUT OFF BUILDING WATER SERVICE DURING CITY INSPECTION TEST.
  5. WAIT 30 MINUTES AND REFILL TO MARK.
  6. TEST PASSES IF WATER REFILLED IS FOUR (4) OR LESS GALLONS FOR FOUR (4") INCH OR SIX (6") INCH LATERAL.
- ALTERNATE 2 -
1. INSTALL OR USE EXISTING CLEAN-OUT OR FIXTURE AT THE FOUNDATION LEVEL (FLOOR JOIST LEVEL) OR SLAB FLOOR LEVEL..
  2. CONTINUE TEST AS IN ALTERNATE 1.

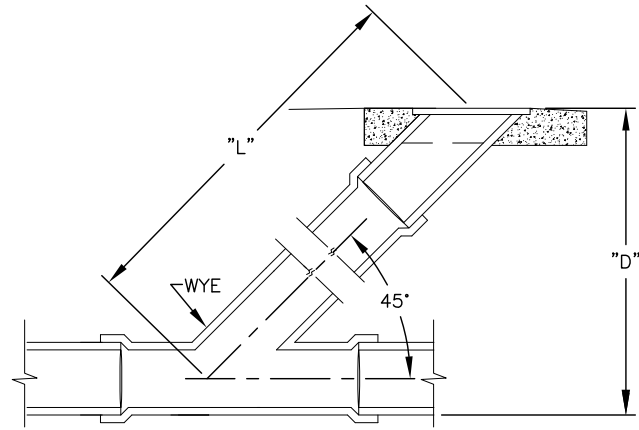

LENGTH OF THE RISER AT 45 DEGREES (IN FEET) "L"	VERTICAL DEPTH TO LATERAL AT CLEAN-OUT (IN FEET) "D"	TEST PRESSURES MINIMUM OF 4 PSI (IN PSI) SEE NOTE # 1
1	0.7	0.7
2	1.4	1.4
3	2.1	2.1
4	2.8	2.8
5	3.5	3.5
6	4.2	4.2
7	4.9	4.9
8	5.7	5.7
9	6.4	6.4
10	7.1	7.1
11	7.8	7.8
12	8.5	8.5
13	9.2	9.2
14	9.9	9.9
15	10.6	10.6
16	11.3	11.3

NOTE:

1. GROUND WATER IS ASSUMED AT 3'-0" BELOW GRADE.



**SEWER LATERAL TEST (AIR)  
CITY ORDINANCE #1329**

**DEPARTMENT OF PUBLIC WORKS**

APPROVED BY

DATE

8/17/2006

DRAWING NO.

**SS-2**  
(4 of 4)

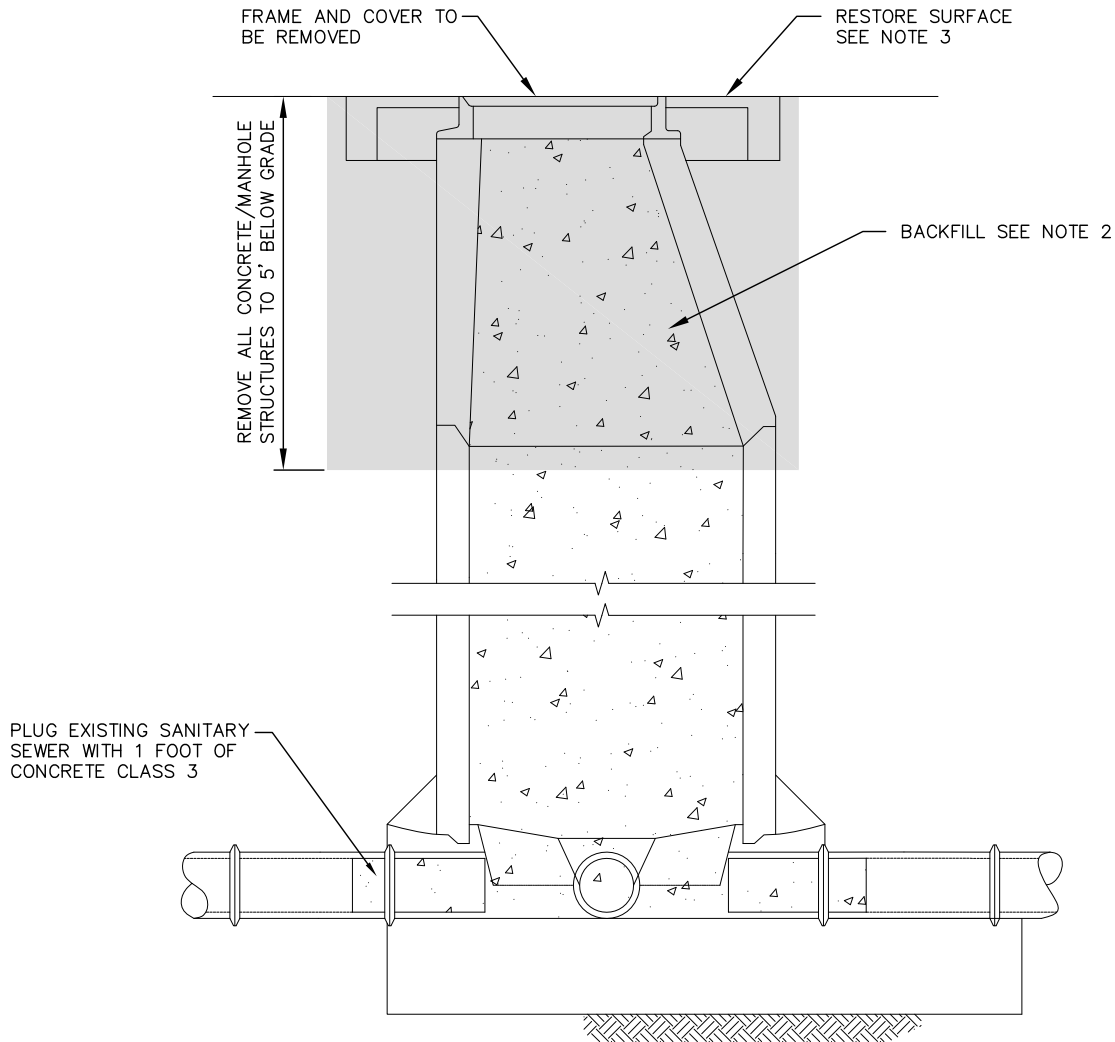

THE EXISTING MANHOLE TO BE ABANDONED IN PLACE SHALL BE AS SHOWN ON PLANS AND IN ACCORDANCE WITH THE FOLLOWING REQUIREMENTS AND STANDARD SPECIFICATIONS:

1. REMOVE AND SALVAGE ALL SUITABLE FRAMES AND LIDS (TO BE DETERMINED BY THE CITY) AND DELIVER TO THE CITY'S YARD. UNSUITABLE FRAMES AND LIDS SHALL BECOME THE PROPERTY OF THE CONTRACTOR AND SHALL BE DISPOSED OF OUTSIDE OF THE PUBLIC RIGHT-OF-WAY IN ACCORDANCE WITH SECTION 7-1.13 OF THE STANDARD SPECIFICATIONS.
2. IN TRAFFIC AREA, FILL WITH 1.5 SACK CDF OR CLASS 2 AGGREGATE BASE AT 95% RELATIVE COMPACTION. IN NON-TRAFFIC AREA, FILL WITH NATIVE SOIL.
3. RESTORE THE SURFACE TO A CONDITION TO MATCH EXISTING PAVEMENT, BUT NOT LESS THAN 6" A.C. SURFACE.



**ABANDONMENT OF EXISTING  
SANITARY SEWER MANHOLE**

**DEPARTMENT OF PUBLIC WORKS**

APPROVED BY  
DATE  
12/27/06

DRAWING NO.  
**SS-4**